

Overview of Vapor Absorption Cooling Systems

An Online Continuing Education Course for Engineers

Course Number: HV-4002

Credit: 4 Hours / 4 PDH / 4 CPD

Overview of Vapor Absorption Cooling Systems

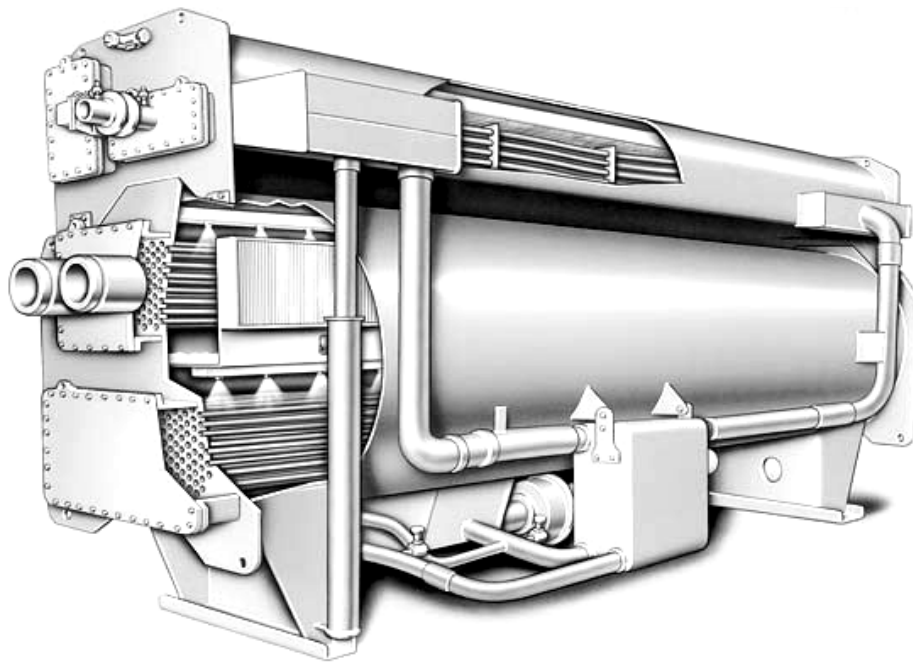

Course Content

A vapor absorption chiller machine (VAM) is a machine that produces chilled water using a heat source rather than electrical input as in the more familiar vapor compression cycle. It seems unreasonable that cooling can be achieved with heat, but that is what occurs within an absorption chiller.

Both vapor compression and absorption refrigeration cycles accomplish the removal of heat through the evaporation of a refrigerant at a low pressure and the rejection of heat through the condensation of the refrigerant at a higher pressure. The basic difference is that an electric chiller employs a mechanical compressor to create the pressure differences necessary to circulate the refrigerant whereas the absorption chillers use heat source and do not use a mechanical compressor. The differences cause an absorption system to use little to no work input, but energy must be supplied in the form of heat. This makes the system very attractive when there is a cheap source of heat, such as solar heat or waste heat from electricity or heat generation.

Absorption chillers have recently gained widespread acceptance due to their capability of not only integrating with cogeneration systems but also because they can operate with industrial waste heat streams.

What is Absorption?

Comparing the absorption refrigeration cycle with the more familiar vapor compression refrigeration cycle is often an easy way to introduce it.

The standard vapor compression refrigeration system is a condenser, evaporator, throttling valve, and a compressor. Figure below is a schematic of the components and flow arrangements for the vapor compression cycle.

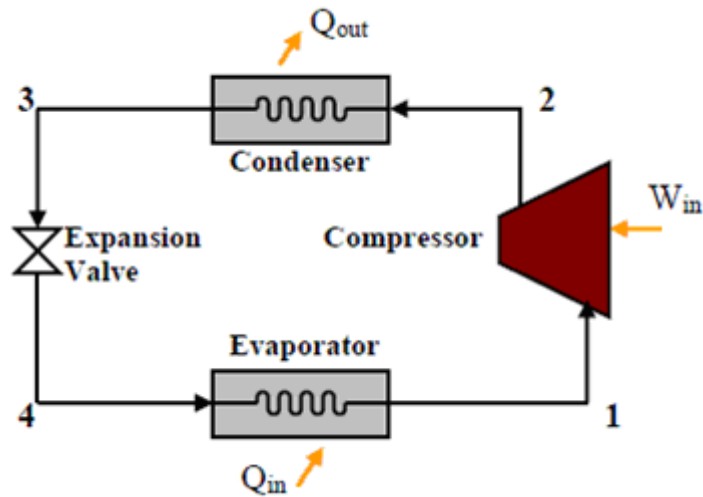

Vapor Compression Cycle

In the vapor-compression refrigeration cycle, refrigerant enters the evaporator in the form of a cool, low-pressure mixture of liquid and vapor (4). Heat is transferred from the relatively warm air or water to the refrigerant, causing the liquid refrigerant to boil. The resulting vapor (1) is then pumped from the evaporator by the compressor, which increases the pressure and temperature of the refrigerant vapor.

The hot, high-pressure refrigerant vapor (2) leaving the compressor enters the condenser where heat is transferred to ambient air or water at a lower temperature. Inside the condenser, the refrigerant vapor condenses into a liquid. This liquid refrigerant (3) then flows to the expansion device, which creates a pressure drop that reduces the pressure of the refrigerant to that of the evaporator. At this low pressure, a small portion of the refrigerant boils (or flashes), cooling the remaining liquid refrigerant to the desired evaporator temperature. The cool mixture of liquid and vapor refrigerant (4) travels to the evaporator to repeat the cycle.

Much like in the vapor compression cycle, refrigerant in the absorption cycle flows through a condenser, expansion valve, and an evaporator. However, the absorption cycle uses different refrigerants and a different method of compression than the vapor compression cycle.

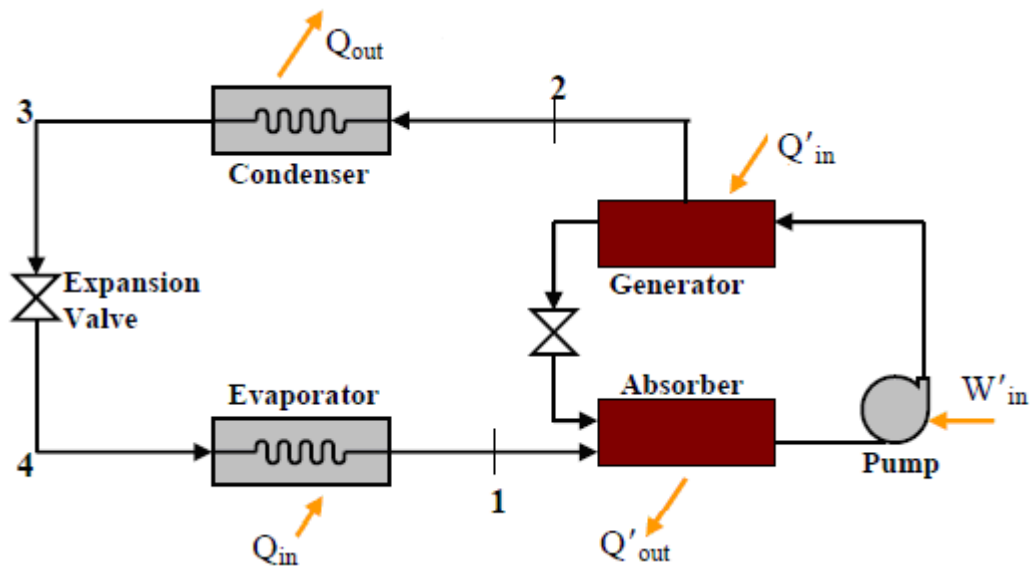

Vapor Absorption Cycle

Absorption refrigeration systems replace the compressor with a generator and an absorber. Refrigerant enters the evaporator in the form of a cool, low-pressure mixture of liquid and vapor (4). Heat is transferred from the relatively warm water to the refrigerant, causing the liquid refrigerant to boil. Using an analogy of the vapor compression cycle, the absorber acts like the suction side of the compressor—it draws in the refrigerant vapor (1) to mix with the absorbent. The pump acts like the compression process itself—it pushes the mixture of refrigerant and absorbent up to the high-pressure side of the system. The generator acts like the discharge of the compressor—it delivers the refrigerant vapor (2) to the rest of the system.

The refrigerant vapor (2) leaving the generator enters the condenser, where heat is transferred to water at a lower temperature, causing the refrigerant vapor to condense into a liquid. This liquid refrigerant (3) then flows to the expansion device, which creates a pressure drop that reduces the pressure of the refrigerant to that of the evaporator. The resulting mixture of liquid and vapor refrigerant (4) travels to the evaporator to repeat the cycle.

Similarities between Vapor compression and Vapor absorption cycles

The basic absorption chiller cycle is similar to the traditional vapor compression chiller cycle in that

1. Both cycles circulate refrigerant inside the chiller to transfer heat from one fluid to the other;
2. Both cycles include a device to increase the pressure of the refrigerant and an expansion device to maintain the internal pressure difference, which is critical to the overall heat transfer process;
3. Refrigerant vapor is condensed at high pressure, rejecting heat to the cooling medium.

To view the remainder of the course material and to take the quiz for PDH credit, you must purchase the course.

Close this window and click "Add to cart" on the product page.

- ...cycle generally uses a refrigerant (R-22, HCFC-22, HFC-134a, etc) as the refrigerant;
4. Compared to compression chillers, absorption systems contain very few moving parts, offer less noise and vibration, are compact for large capacities and require little maintenance;