



# Lithium-Ion Batteries for Electric Vehicles and Transport Decarbonization

An Online Continuing Education Course for Engineers

**Course Number: E-6011**

**Credit: 6 Hours / 6 PDH / 6 CPD**

# Lithium-Ion Batteries for Electric Vehicles and Transport Decarbonization

A. Bhatia, Mechanical Engineer

The automotive industry is quickly moving away from traditional internal combustion (IC) engines towards electric vehicles (EVs). The global fleet of light-duty EVs grew from a few thousand just a decade ago to around 10 million vehicles in 2020.

The growing acceptance of EVs is the outcome of technological advancements made in energy storage batteries coupled with their falling cost and fast charging capabilities. Further, with the need to deal with global environmental problems and growing interests in decarbonization, attention is being directed toward solutions to the problems of energy use. The EVs that use rechargeable batteries for traction have been commercialized, and their use is rapidly becoming more widespread due to both their environmental performance and economics.

Lithium-Ion (Li-ion) battery technology is currently the dominant core enabling technology for EVs and electronic gadgets. The Li-ion battery packs used in electric cars are like those used in cell phones and laptop computers, only they're much larger. They're far different than the heavy Lead-Acid batteries used in conventional cars and have a much higher energy density. New cell chemistries are being introduced to make batteries lighter and store enough energy in smaller packs so that EVs can provide increasing drive range per recharge. Major breakthroughs in material chemistries are still required to achieve a longer travel range per recharge (> 500 km) at lower costs (< \$125/kWh).

This course gives an overview of EV technologies, Li-ion batteries, their limitations, safety concerns, and the emerging battery technologies to meet future requirements. The topics provide a good knowledge base not only for those working daily on electrochemical energy storage but also for scientists, engineers, and students concerned with modern battery systems.

## Key Learning

- Overview of electric vehicles and batteries
- Types of electrical vehicles – all-electrical vehicle, hybrid vehicles, and plug-in hybrid vehicles
- Working principle of batteries and the key performance indicators
- Types of rechargeable batteries and comparison of Lead-Acid, Ni-MH, and Lithium-Ion batteries
- Cathode and anode material chemistries of Lithium-Ion batteries
- Characteristics of Lithium-Ion batteries best suited for electric vehicles
- Construction and assembly of batteries cells, modules, and packs
- Sourcing, costing, transportation, and disposal of Lithium-Ion batteries
- AC and DC charging systems for Lithium-Ion batteries
- Safety issues and battery management system
- Next-generation technologies and innovations

## Table of Contents

Chapter 1: Overview of Electric Vehicles .....	5
1.1 Electric Vehicles (EVs) .....	5
1.2 Comparison of IC Engine Vehicles v/s Electric Vehicles.....	8
1.3 Battery Technology.....	10
1.4 Key Performance Indicators for Electric Vehicles .....	12
1.5 Lithium Ion Battery Pack for EVs.....	15
1.6 Challenges Facing EVs .....	16
Chapter 2: Types of Electric Vehicles (EVs).....	21
2.1 Types of EVs .....	22
2.2 All-Electric Vehicle (AEV).....	22
2.3 Hybrid Electric Vehicles (HEV).....	23
2.4 Plug-in hybrid electric vehicles (PHEVs).....	26
2.5 Efficiency Features of EVs .....	26
2.6 Commercialization of EVs .....	28
2.7 Type of Batteries for EVs.....	31
Chapter 3: Battery Basics .....	34
3.1 Working Principles of Battery .....	34
3.2 Classification of Batteries.....	36
3.3 Battery Characteristics .....	37
3.4 Battery Definitions, Terms & Terminology .....	44
Chapter 4: Rechargeable Batteries .....	48
4.1 Lead-Acid batteries .....	48
4.2 Nickel–Cadmium (Ni–Cd) Battery .....	50
4.3 Nickel–Metal Hydride (Ni–MH) Battery .....	51
4.4 Lithium-Ion (Li-ion) Battery.....	52
4.5 Selection Considerations.....	54
Chapter 5: Lithium-Ion Batteries.....	58
5.1 Types of Lithium Batteries .....	58
5.2 Lithium-Ion Battery Fundamentals .....	59
5.3 Lithium-Ion Battery Materials.....	62
5.4 Cathode Materials.....	62

5.5	Negative Electrode (Anode) Materials.....	65
5.6	Electrolyte Chemistry.....	67
5.7	Separator.....	67
5.8	Comparison of Li-ion Battery Chemistries .....	68
5.9	Commercial Application of Li-ion Batteries .....	70
Chapter 6: Battery Cells, Modules & Packs.....		74
6.1	Battery Cell Construction.....	75
6.2	Lithium-Polymer Batteries .....	78
6.3	Battery Modules .....	79
6.4	Battery Packs.....	79
6.5	Value Chain – Manufacturers .....	80
Chapter 7: Lithium-Ion Battery Charging Equipment .....		85
7.1	Conditions for Lithium-Ion Battery Charging.....	85
7.2	EV Battery Charging Stations .....	86
7.3	Charging Regulations & Standards.....	89
Chapter 8: Issues & Challenges with Lithium-Ion Batteries.....		91
8.1	Capacity Fading .....	91
8.2	Safety Issues.....	92
8.3	Safety with Battery Management System (BMS) .....	95
8.4	Li-ion Batteries Safety & Usage Guidelines.....	95
8.5	Safety Testing.....	97
8.6	Disposal.....	97
Chapter 9: Technology, Challenges & The Future.....		98
9.1	Next-generation Technologies and Innovations.....	99

## 1 Chapter 1: Overview of Electric Vehicles

The automotive industry is fast moving away from traditional internal combustion (IC) engines towards electric vehicles (EVs). The global fleet of light-duty EVs grew from a few thousand just a decade ago to around 10 million vehicles in 2020. The growing acceptance of EVs is the outcome of several factors: technological advancements and improvements in energy storage of batteries coupled with their falling cost, fast charging capabilities, and growing interests in global environmental issues and decarbonization.

Currently, Lithium-Ion (Li-ion) battery technology is the core enabling technology for EVs. Li-ion batteries, like any other battery, store energy chemically and release the same electrically. Inside, Lithium-Ion cells allow large amounts of energy to be squeezed into a very small package that enables faster energy extraction. New cell chemistries are being introduced to make batteries lighter and store enough energy in smaller packs so that EVs can provide increasing drive range per recharge.

Major breakthroughs in material chemistries are still required to achieve the needs of the fast-growing EV market, which include increasing the real range of electric cars from 300 to 600 km without recharging, reducing charging times to less than 15 minutes, and achieving cost competitiveness with IC engines.

### 1.1 Electric Vehicles (EVs)

Electric vehicles (EVs) are powered by electricity through series of batteries and drive motors in place of IC engines in conventional vehicles.

Sure, all our cars have batteries already, but they're just to start an IC engine, then the fuel does all the work. In contrast, EV's gets their entire energy from batteries for traction. EV battery packs generally contain a series of connected individual cell modules stacked together to provide a pretty high voltage of 100-400 volts to run an EV. A well-charged battery can be used for up to 200 kms on a single charge, depending on the battery capacity.

Compared to conventional fuel vehicles, the EVs have much-simplified drive trains. They do not require clutch or multi-speed transmissions because the electric motors produce a consistent amount of torque instantly at any given RPM within a specific range. The differential gear is replaced by using one or two traction motors to drive front wheels. Depending upon the complexity of design, the drive motor of EV can be a single reversible motor/generator or individual motors and generator.

Three major parts make the electric car work: the motor, the controller, and the batteries. The controller acquires power from the batteries and delivers it to the motor. The accelerator pedal connects with the potentiometer, which provides the information to the controller as to how much power is needed by the motor.

The basic structure of an EV is shown in the figure below.

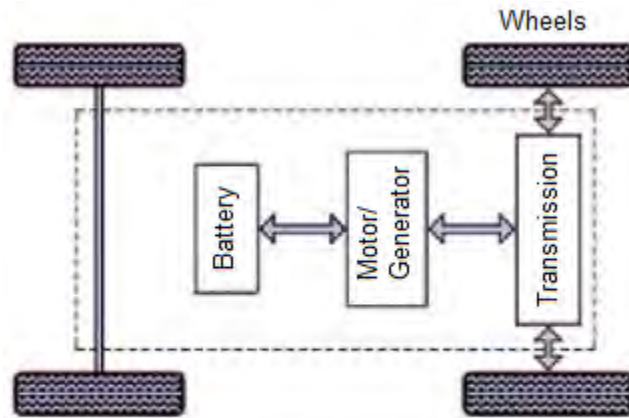

**Basic Structure of an Electric Vehicle**

The battery pack is one of the most important and critical components of an EV and is the major contributor to the cost of EV. Broadly, there are two types of EVs: plug-in hybrid vehicles and all-electric vehicles.

- a. Hybrid vehicles use a gasoline engine and an electric motor. The battery-powered motor can provide a performance boost to the gasoline engine.
- b. For all-electric vehicles, the battery provides the power. With a battery pack, the vehicle can provide traction.
- c. The battery-powered motor can provide a performance boost to the gasoline engine.
- d. The battery-powered motor can provide a performance boost to the gasoline engine.
- e. The battery-powered motor can provide a performance boost to the gasoline engine.

The battery also serves as a power source for the vehicle's accessories, such as air conditioning, power windows, and power locks. The battery pack is rechargeable and can be charged externally or internally.

The figure below shows the basic structure of an electric vehicle. The battery pack, motor, and transmission are connected to the wheels. The battery pack and motor can be stored in the vehicle's chassis.

*To view the remainder of the course material and to take the quiz for PDH credit, you must purchase the course.*

*Close this window and click "Add to cart" on the product page.*