



Introduction to DC Power Plant Design

An Online Continuing Education Course for Engineers

Course Number: E-2039

Credit: 2 Hours / 2 PDH / 2 CPD

Introduction to DC Power Plant Design

Joseph B. Kumor, P.E.



A Telecom Central Office

1.0 Introduction

This course provides an overview of the components of a DC (Direct Current) power plant as used in the telecommunications industry. However, the practical knowledge and skills covered herein are not limited to one industry and may be applied to other businesses that are suitable for a DC power plant. As an example, DC power has been recommended for facilities with large computer processing requirements, such as data centers. To understand why DC power continues to be the de facto standard in the telecommunications world to this day, it is useful to start with a brief examination of telecom.

Telecommunications is the electronic transmission of information from point A to point B. If your service provider is a local telephone company, then your home or office most likely uses copper or fiber facilities to connect your phone and/or computer to a central office (CO) building. Cell phone connections also route through these central offices because the cell phone carriers lease communication lines from the local exchange telephone companies to link their cell towers to their Mobile Telephone Switching Offices (MTSOs). It is essential that the network of communications equipment serving our homes and businesses is always available for contacting police, fire, medical personnel, and others as needed. To make this happen, power must be available to the network equipment at all times.

Alexander Bell received a patent for the telephone in 1876. Telecommunications equipment has since evolved dramatically with the advances in electronics, fiber optics, and the internet. Commercial power generation began when Thomas Edison began selling DC electricity from the NYC Pearl Street Power Station in 1882. Commercial power stations began generating AC (Alternating Current) after Nikola Tesla and George Westinghouse opened their Power Station at Niagara Falls in 1895. Although AC power has advantages when being transmitted over long distances, DC power has significant advantages when used for powering in-building electronic equipment. The CO power equipment has benefited from advances in electronics, but today fundamentally provides the same functions that have been provided for over 100 years. CO power does not get the visibility in the telecom industry that the latest router or high-speed multiplexer does, but it is a critical part of the network. Nothing works without power.

At the core of the central office power system is the use of DC. Today's large data centers can be made to run more efficiently if they too ran on a DC based system. Data centers use UPSs (Uninterruptible Power Supplies) which must convert the incoming AC to DC to charge batteries and then convert the DC back to AC for distribution to the equipment. At the equipment, the AC is then again converted back to DC for use within the silicon-based equipment. These conversions produce heat which puts a demand on their air conditioning systems. These AC to DC and DC to AC conversions are potential failure points in the

distribution of power. The engineers designing the new data centers can take advantage of DC power to increase reliability and efficiency.

This course will examine the basic engineering design of the telecom central office power system. The advantages of using -48 VDC (Voltage Direct Current) are addressed. These systems are built for redundancy to ensure the power is always available to the network equipment. We will also review OR'd circuits which contribute to the reliability of the network when designed correctly. Provisioning adequate battery capacity will be addressed for when the AC power may not be available. Because the CO infrastructure is DC based, voltage drops must be compensated for, so we will examine how to size the copper power cables. We will also look at how the plant loads are measured.

2.0 Components of the Power System

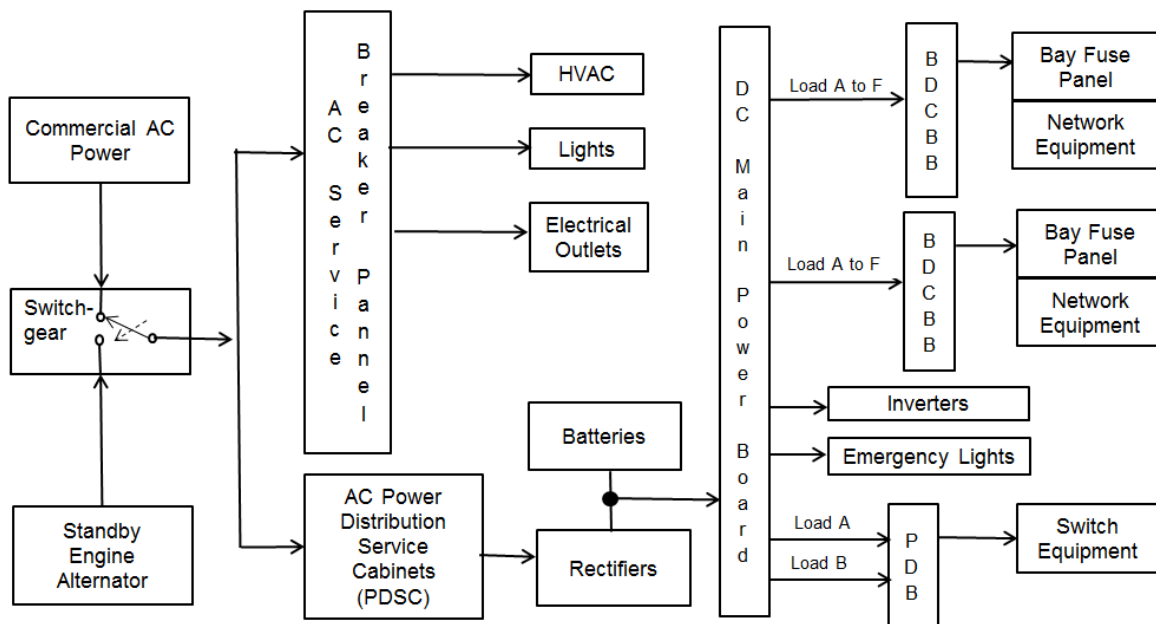

Figure 2.1 Block Diagram of the Central Office Power System

2.1 AC Components

The Central Office is supplied commercial electrical power from the local power company. Telecom central offices are usually supplied with three phase power unless they are small in which case the office would operate on single phase power. Equipment such as motors and

rectifiers may be damaged if the incoming AC is not of good quality. If one phase of the incoming power drops below certain thresholds equipment may be damaged. Power utilities may also purposely drop the line voltage during times of peak demand in an attempt to reduce their load. (Power = V^2 / R). This is a brownout. The power company may also initiate a blackout which is the complete loss of power. An accident may damage a transformer which could present a problem to the incoming power. Voltage sags and surges are also a measure of power quality.

The Switchgear is constantly monitoring the incoming power quality. If the power does not meet requirements, the switchgear will send a signal to start the standby engine and alternator. Within a minute or two, the alternator will be ready to supply the office with power. When the switchgear senses that the engine provided power is acceptable, it will automatically switch to the standby engine alternator. There may be some central offices where the switchgear is operated manually, but this is discouraged as those offices must have additional batteries available to supply power until a technician can get on-site to start the engine. Batteries will supply power to the network equipment until the switch can be made to the standby engine alternator.

The engine alternator must be run routinely to ensure its readiness for when commercial power is lost. This is accomplished by manually operating the switchgear. During a test run, the engine start batteries must be checked for proper voltage and any leakages. The engine must be checked for any leaks including fuel, oil, and coolant. Proper voltages should be recorded for each voltage phase and the engine must be capable of carrying the office load. If the engine cannot carry the office load, certain non-essential loads must be shed i.e. breakers would have to be manually tripped. This is a stop gap measure called load shedding and should only be in place until a larger engine alternator can be put in place.

Some power utilities offer a load curtailment agreement with their customers. This requires the telecom to run their engine during times when the utility is experience peak load demand. This relieves the load demand from the power utility which may reduce the need for brownouts or rolling blackouts. In return, the telecom gets a credit on their bill from the power company.

First responders need to understand how the central office power systems function especially when responding to an electrical fire in a central office. Many central offices do not have a fire suppression system such as a sprinkler system or a system to disperse a halogenated agent, so a fire may continue to burn. To stop the electricity from feeding the fire, first responders may have the commercial power to the building disconnected. This will automatically start the standby engine alternator which will provide the same power as the commercial utility provider. When the engine is stopped, batteries will continue to provide power to the fire. The

only way to stop providing DC power to the fire would be to trip the appropriate circuit breakers. In the meantime, it is likely that noxious gases from the burning cables and equipment would be produced.

There are three availability levels of AC power in the CO. The first is commercial AC power only which does not operate through the switchgear. Commercial only power may be used to provide power to specific areas of the building such as an administrative area that can safely tolerate a power outage without damaging network equipment. Protected AC power operates off the standby engine alternator. The switchgear will connect to protected AC as soon as the engine alternator has come up to speed. Protected AC power includes HVAC (Heating, Ventilation, & Air Conditioning), non-emergency lights, rectifiers, and non-emergency electrical outlets. While the office is transitioning to protected power, the telecommunications equipment will operate off the batteries. Essential power is always available as it runs off inverters that are connected to the office batteries. The inverters convert the DC to AC power.

The AC Service Breaker Panel will connect power to the building loads including HVAC, lights, and electrical outlets. The AC Power Distribution Service Cabinets (PDSCs) supply power to the rectifiers.

2.2 Rectifiers

The rectifiers convert the AC to DC to keep the batteries at the manufacturer's recommended float voltage. The float voltage is high enough to keep the batteries fully charged and provides power to the equipment, so that the office loads are being supplied power from the rectifiers and not the batteries during normal operation.

When sizing rectifiers, it's important to consider the planned load in the office at the end of some period of time, usually 2 years. This is because adding rectifiers may require a new PDSC Cabinet or an addition to an existing cabinet. Rectifier capacity should be available to supply the DC loads and be able to recharge the batteries in 24 hours or less. This requires an additional 20% of DC current from the rectifiers over the office load.

Example 2.2a

200-amp rectifiers are available; Total planned office DC load demand (batteries and equipment) is 750 amps in 2 years.

Determine how many 200-amp rectifiers are required.

Solution:

Recharge capacity required = 20% of 750 = 150 amps

Total amps required = 750 + 150 = 900 amps

5 200-amp rectifiers are required $(5) \cdot (200) = 1,000$ amps

A maintenance spare rectifier needs to be available to provide office loads if one rectifier fails. The maintenance spare rectifier may be included in the recharge capacity as in Example 2.2a. Only 4 rectifiers are needed to carry the normal loads, and the fifth rectifier is the maintenance / recharge rectifier.

Example 2.2b

400-amp rectifiers are available; Total office planned DC load demand is 600 amps.

Determine the number of

Solution:

Recharge capacity

Total amps require

3 400-amp rectifier

maintenance spare

To view the remainder of the course material and to take the quiz for PDH credit, you must purchase the course.

3rd to provide

If rectifier capacity is

plants voltage until t

may be damaged and

Close this window and click "Add to cart" on the product page.

er time, dropping the

discharge too much, they

2.3 DC Components

The batteries and rectifiers are connected to the Main Power Board (MPB). There are no fuses or circuit breakers between the batteries, the rectifiers, and the power board. The voltage at this MPB is called the float voltage which ranges from 52 to 55 volts. However, at this low voltage the current normally ranges from 400 to 5000 amps. Any Emergency Power Off (EPO) switch would have to be sized to handle this current. Additionally, any switch used to restore power from individual battery strings that were turned off would be subject to small variance in voltage between the battery strings that would cause arcing. When connecting a new battery string to the plant, manufacturers require that the voltage difference between the new string and the existing plant be less than 0.05 volts to limit the arcing.

The DC Main Power Board connects to multiple Battery Distribution Circuit Breaker Bays (BDCBBs). Prior to the BDCBBs, fuses were used, and the bay was referred to as the Battery